

K2 SMARTSET™ GEAR DRIVEN SPRINKLER SETTING INSTRUCTIONS

NOTE: The K2 SmartSet is factory preset with a 90° arc setting, and includes a pre-installed #2.5 nozzle.

CHANGING A NOZZLE

1 ► REMOVING THE NOZZLE RETENTION SCREW

Use your K-Key or a flat blade screwdriver to remove the nozzle retention screw by turning counter-clockwise to remove and clockwise to re-install.

2 ► PULL UP THE RISER

Insert the K-Key in the keyhole on the top of the nozzle turret and turn the key 1/4 turn to insure that the key does not slip out of the keyhole when you pull it up. Firmly pull up the entire spring-loaded riser to access the nozzle socket. Hold the riser assembly up with one hand.

3 ► REMOVING THE NOZZLE

With the nozzle retention screw removed, insert the K-Key into the slot directly under the nozzle “prongs” at the top of the nozzle. Now, turn the key 1/4 turn to “hook” the nozzle and pull the nozzle out.

4 ► INSTALLING A NOZZLE

Press the desired nozzle into the nozzle socket. Make sure the nozzle number is visible and the nozzle “prongs” are up. Then, re-install the nozzle retention screw. **NOTE:** The nozzle retention screw is also a break-up screw and used to adjust the distance of the spray.

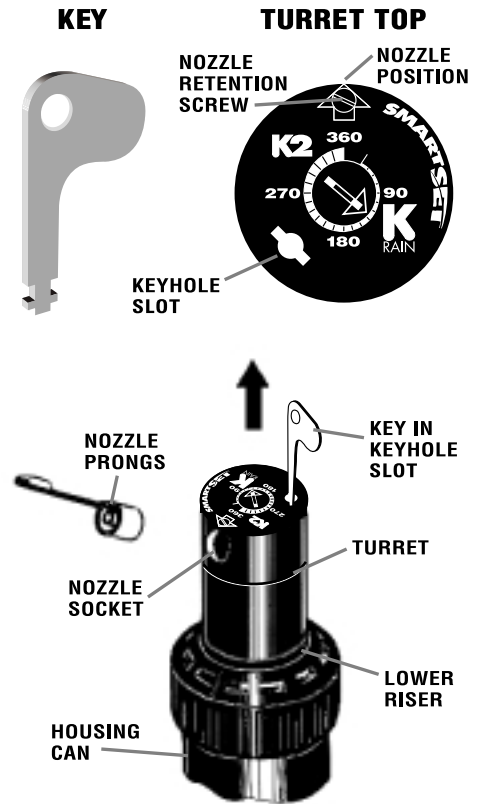

SETTING THE ARC ADJUSTMENT

1 ► FINDING THE LEFT START POSITION

Place your finger on the top center of the nozzle turret. Rotate the turret to the right until it stops and then back to the left until it stops. Notice the position of the nozzle arrow. This is the “Left Start” position. The sprinkler will begin spraying from this position and rotate clockwise until it reaches the right Adjustable Stop-Return Point.

2 ► ORIENTING THE LEFT START POSITION

Insert the K-Key in the keyhole on the top of the nozzle turret and turn the key 1/4 turn to insure that the key does not slip out of the keyhole when you pull it up. Being careful not to allow the nozzle turret to turn, firmly pull up the entire spring-loaded riser. Hold the lower riser assembly up with one hand. Now turn only the lower riser clockwise or counter-clockwise until the nozzle arrow is pointing where you want the sprinkler to begin spraying.

3 ► CHANGING THE ARC

Insert the K-Key or a flat blade screwdriver into the Arc Set Adjustment slot. Turn clockwise to increase the arc or counter-clockwise to decrease the arc.

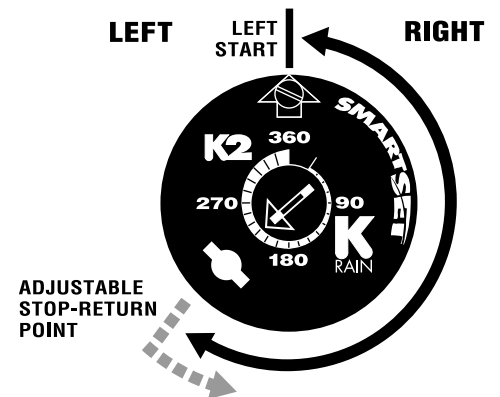

**ARC SELECTION:
40° TO 360°**

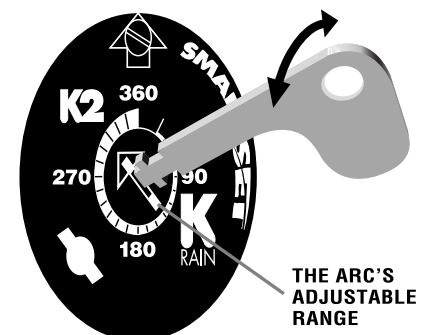

WHEN SET AT 360°, THE K2 SMARTSET WILL ROTATE CONTINUOUSLY IN A CLOCKWISE DIRECTION.

K2 SMARTSET™ GEAR DRIVEN SPRINKLER SETTING INSTRUCTIONS

SPRINKLER INSTALLATION

1 ► INSTALL AND BURY

Do not use pipe dope. Thread the sprinkler on the pipe. Bury the sprinkler flush to grade. **NOTE:** Gear driven sprinklers and pop-up sprays should not be installed on the same watering zone.

2 ► INSPECTING THE FILTER

Unscrew the top and lift the complete sprinkler assembly out of the housing can. The filter is located on the bottom of the sprinkler assembly and can easily be pulled out, cleaned and re-installed.

3 ► WINTERIZATION TIPS

When using an air compressor to remove water from the system please note the following:

- 1) Do not exceed 30 PSI.
- 2) Always introduce air into the system gradually to avoid air pressure surges. Sudden release of compressed air into the sprinkler can cause damage.
- 3) Each zone should run no longer than 1 minute on air. Sprinklers turn 10 to 12 times faster on air than on water. Over spinning rotors on air can cause damage to the internal components.

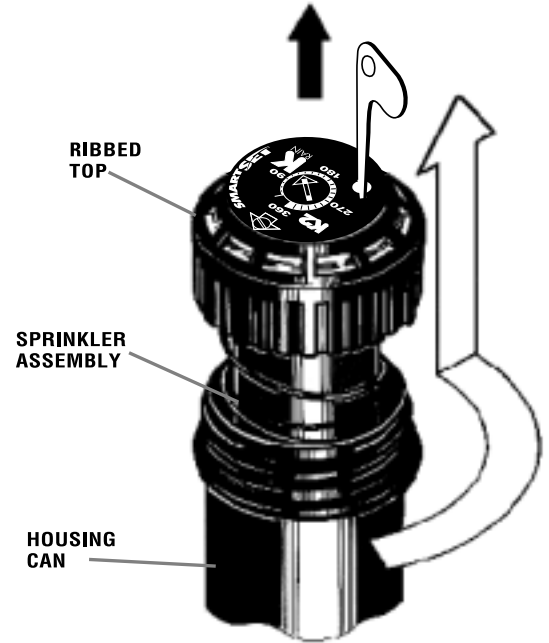

STANDARD PERFORMANCE DATA

NOZZLE	PRESSURE			RADIUS		FLOW RATE			PRECIP in/hr		PRECIP mm/hr	
	PSI	kPa	Bars	Ft.	M.	GPM	L/M	M ³ /H	■	▲	■	▲
#1	30	207	2,1	30	10,1	1,2	4,5	0,3	0,21	0,25	5	6
	40	276	2,8	31	10,1	1,3	4,9	0,3	0,23	0,27	6	7
	50	345	3,4	31	10,1	1,5	5,7	0,3	0,27	0,31	7	8
	60	414	4,1	32	10,1	1,8	6,8	0,4	0,32	0,37	8	9
#1.5	30	207	2,1	36	11,0	1,5	5,7	0,3	0,22	0,26	6	6
	40	276	2,8	37	11,3	1,8	6,8	0,4	0,25	0,29	6	7
	50	345	3,4	37	11,3	2,0	7,6	0,5	0,28	0,32	7	8
	60	414	4,1	38	11,6	2,2	8,3	0,5	0,29	0,34	7	9
#2	30	207	2,1	35	10,7	1,8	6,8	0,4	0,28	0,33	7	8
	40	276	2,8	35	10,7	2,2	8,3	0,5	0,35	0,40	9	10
	50	345	3,4	36	11,0	2,6	9,8	0,6	0,39	0,45	10	11
	60	414	4,1	38	11,6	2,9	11,0	0,7	0,39	0,45	10	11
#2.5 Pre-installed	30	207	2,1	37	11,3	2,5	9,5	0,6	0,35	0,41	9	10
	40	276	2,8	38	11,6	3,0	11,4	0,7	0,40	0,46	10	12
	50	345	3,4	40	12,2	3,4	12,9	0,8	0,41	0,47	10	12
	60	414	4,1	40	12,2	3,8	14,4	0,9	0,46	0,53	12	13
#3	30	207	2,1	36	11,0	3,0	11,4	0,7	0,45	0,51	11	13
	40	276	2,8	37	11,3	3,4	12,9	0,8	0,48	0,55	12	14
	50	345	3,4	38	11,6	4,0	15,1	0,9	0,53	0,62	13	16
	60	414	4,1	41	12,5	4,4	16,7	1,0	0,50	0,58	13	15
#4	30	207	2,1	37	11,3	4,0	15,1	0,9	0,56	0,65	14	16
	40	276	2,8	39	11,9	4,5	17,0	1,0	0,57	0,66	14	17
	50	345	3,4	39	11,9	5,2	19,7	1,2	0,66	0,76	17	19
	60	414	4,1	40	12,2	5,6	21,2	1,3	0,67	0,78	17	20
#5	30	207	2,1	37	11,3	4,8	18,2	1,1	0,68	0,78	17	20
	40	276	2,8	38	11,6	5,6	21,2	1,3	0,75	0,86	19	22
	50	345	3,4	41	12,5	6,5	24,6	1,5	0,74	0,86	19	22
	60	414	4,1	43	13,1	7,2	27,3	1,6	0,75	0,87	19	22
#6	30	207	2,1	40	12,2	6,0	22,7	1,4	0,72	0,83	18	21
	40	276	2,8	41	12,5	6,8	25,7	1,5	0,78	0,90	20	23
	50	345	3,4	42	12,8	7,5	28,4	1,7	0,82	0,95	21	24
	60	414	4,1	44	13,4	8,4	31,8	1,9	0,84	0,96	21	24
#8	30	207	2,1	38	11,6	7,9	29,9	1,8	1,05	1,22	27	31
	40	276	2,8	44	13,4	9,2	34,8	2,1	0,92	1,06	23	27
	50	345	3,4	45	13,7	10,4	39,4	2,4	0,99	1,14	25	29
	60	414	4,1	46	14,0	11,1	42,0	2,5	1,01	1,17	26	30

LOW ANGLE PERFORMANCE DATA

NOZZLE	PRESSURE			RADIUS		FLOW RATE			PRECIP in/hr		PRECIP mm/hr	
	PSI	kPa	Bars	Ft.	M.	GPM	L/M	M ³ /H	■	▲	■	▲
#1.0	30	207	2,1	26	7,9	1,1	4,2	0,2	0,31	0,36	8	9
	40	276	2,8	30	9,1	1,3	4,9	0,3	0,28	0,32	7	8
	50	345	3,4	30	9,1	1,4	5,3	0,3	0,30	0,35	8	9
	60	414	4,1	30	9,1	1,6	6,1	0,4	0,34	0,40	9	10
#1.5	30	207	2,1	27	8,2	1,4	5,3	0,3	0,37	0,43	9	11
	40	276	2,8	28	8,5	1,7	6,4	0,4	0,42	0,48	11	12
	50	345	3,4	31	9,4	1,9	7,2	0,4	0,38	0,44	10	11
	60	414	4,1	30	9,1	2,1	7,9	0,5	0,45	0,52	11	13
#2	30	207	2,1	30	9,1	2,1	7,9	0,5	0,45	0,52	11	13
	40	276	2,8	31	9,4	2,4	9,1	0,5	0,48	0,56	12	14
	50	345	3,4	33	10,1	2,8	10,6	0,6	0,50	0,57	12	14
	60	414	4,1	31	9,4	3,1	11,7	0,7	0,62	0,72	16	18
#3	30	207	2,1	32	9,8	3,0	11,4	0,7	0,56	0,65	14	16
	40	276	2,8	34	10,4	3,5	13,2	0,8	0,58	0,67	15	17
	50	345	3,4	35	10,7	3,9	14,8	0,9	0,61	0,71	15	18
	60	414	4,1	35	10,7	4,3	16,3	1,0	0,68	0,78	17	20

*All precipitation rates calculated for 180° operation. For the precipitation rate for a 360° sprinkler, divide by 2.



K-RAIN MANUFACTURING CORP.
 1640 Australian Avenue
 Riviera Beach, FL 33404 USA
 PH: 561.844.1002 / 1.800.735.7246
 FAX: 561.842.9493
www.krain.com